

Massa TR-1075 Sub-Bottom Profiling Transducers

The Massa Model TR-1075 Family consists of rugged high-power underwater transducers designed to operate in the 2.5 to 10 KHz frequency range. They are ideal for use in bottom mapping and sub-bottom profiling applications.

The transducers are designed to be driven with a maximum input power of 600 Watts using up to a 30% duty cycle, or 200 Watts maximum for continuous operation. In shallow water, the maximum output is cavitation limited. Minimum water depths of approximately 30 and 100 feet are recommended for input power of 200 and 600 Watts respectively to avoid cavitation.

All of the transducers in the family utilize the same resonant structure containing a circular piston for the radiating source that is $\frac{1}{2}$ wavelength in diameter at 4 KHz. The transducers are designed to be bolted directly through their 4-corner integral shock mounts to a simple frame structure. This modular design allows the transducers to easily be assembled into arrays to achieve any desired beam pattern and source level. Each transducer is terminated with a Massa C1F2 Female Underwater Connector and has a locking ring included. Mating C1M2 Male Connectors can be purchased separately.

The TR-1075E consists of the basic resonator with no electrical tuning. Its nominal frequency of resonance is 3.5 KHz. Massa has fabricated TR-1075 Transducers with a wide variety of different internal tuning networks. They have included transformers to produce different output impedance magnitudes. Transducers have been made with both series and parallel tuning to produce a nominal phase angle of 0 at different frequencies. A separate inductor is required for series tuning, while the inductance of the primary windings of the transformer is used for parallel tuning.

In some cases, damping resistors have been connected across the transducer to lower its Q, which allows the use of a short tone burst excitation pulse with reduced sensitivity for operation when very close to the sea floor. These transducers can be driven with greater input power because some of the energy is dissipated by the resistor. Massa can customize a tuning network to meet any requirement, but one of the standard models will usually meet the needs of most customers.



FEATURES

- High Power
 - Up to 600 Watts @ 30% Duty Cycle
 - Up to 200 Watts CW
- Broadband
 - 2.5 to 10 kHz
- Maximum Operating Depth is 2,000 ft.
- True Piston Radiating Source
 - $\frac{1}{2}$ Wavelength Diameter at 4 kHz
 - 80° Conical Beam Angle
- Module Design
 - Shock Mounted
 - Easily Assembled into Arrays
- Weight is 25 lbs.
- Terminated with Proven Reliable C1F2 Underwater Connector
- Mates to Massa C1M2 Underwater Connector

APPLICATIONS

- Sub-Bottom Profiling
- Bottom Mapping

Massa TR-1075 Data

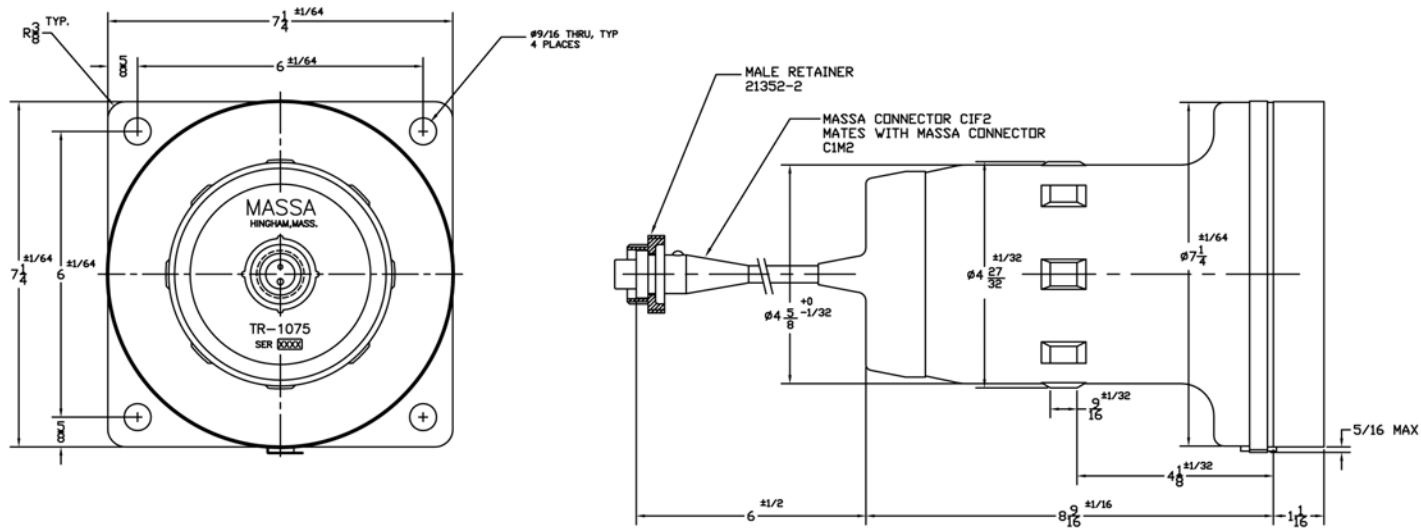

TR-1075 Transducer Family Outline Drawing
(Dimensions in Inches)

Transducer Model Number	Frequency Tuned for 0° Phase (nominal)	Impedance Magnitude (nominal)	Power Rating % Duty Cycle	Tuning Circuit
TR-1075E	No Tuning	4,500 Ohms @ 3.5 kHz	600 Watts @ 30% 200 Watts @ 100%	No Tuning
TR-1075A	4 kHz	100 Ohms @ 4 kHz	600 Watts @ 30% 200 Watts @ 100%	Parallel
TR-1075H	3.5 kHz	200 Ohms @ 3.5 kHz	600 Watts @ 30% 200 Watts @ 100%	Series
TR-1075D	3.5 kHz	200 Ohms @ 3.5 kHz	1,000 Watts @ 30% 335 Watts @ 100%	Series with Shunt Resistor

Chart Showing the Tuning Circuits for the Standard Models of the TR-1075 Transducer Family

Massa TR-1075 Nominal Response Curves

Transmitting Voltage Responses

Receiving Voltage Sensitivities

Impedance Magnitudes

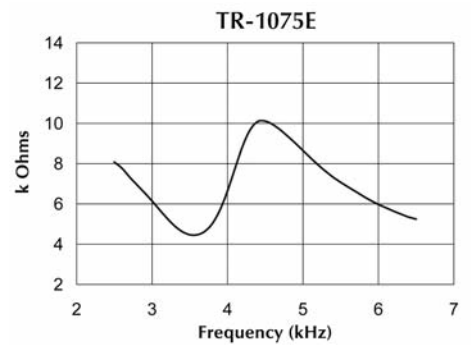
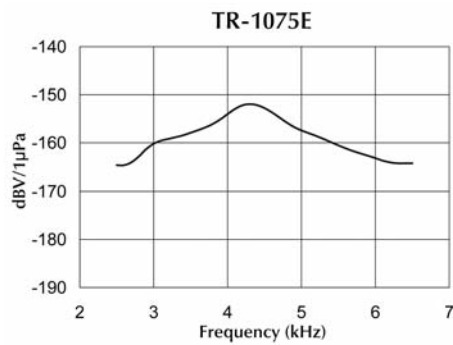
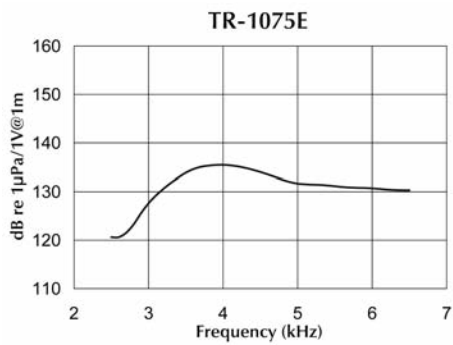
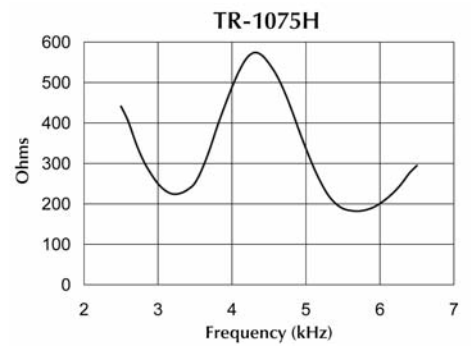
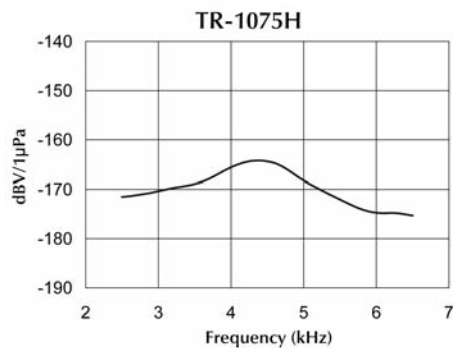
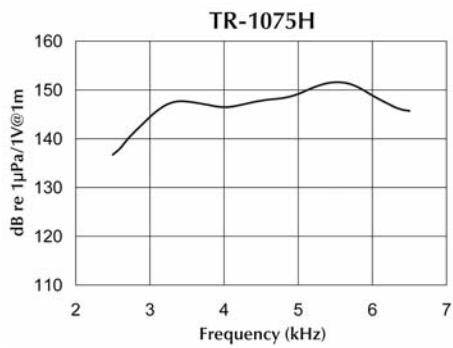
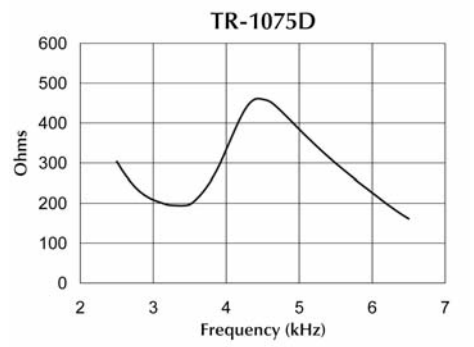
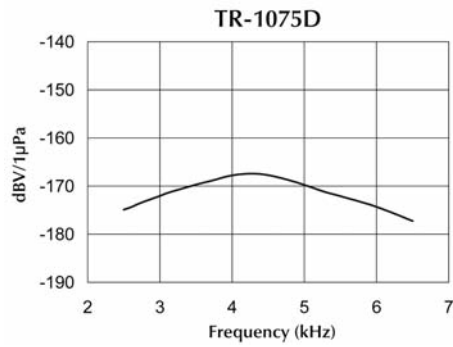
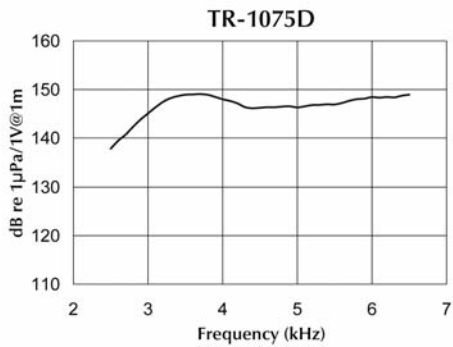
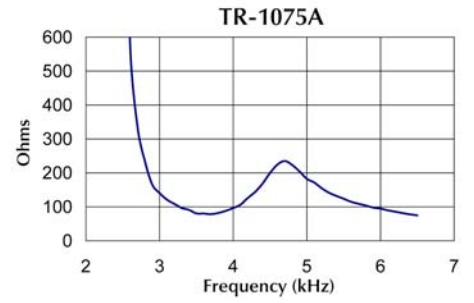
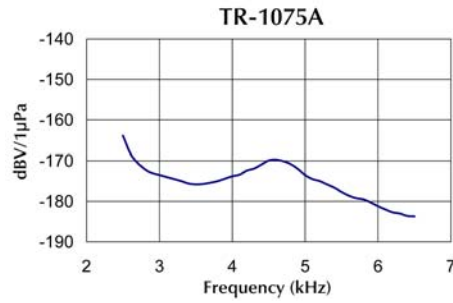
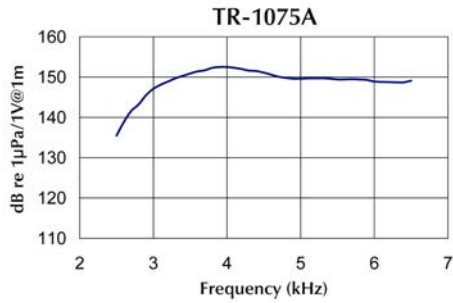

Massa C1M2/C1F2 Underwater Connectors



Photograph of C1M2 and C1F2 Connectors with Retaining Rings

Massa C1M2 male and C1F2 female 2-conductor in-line Underwater Connectors were developed for the oceanographic community to provide highly reliable underwater connection. Massa has manufactured and sold over 100,000 connector pairs, and some have been successfully used for over 20 years in the ocean. There has never been a failure of a connector reported to Massa.

Massa typically supplies transducers with C1F2 Female Connectors attached. C1M2 Male Connectors can be purchased separately to complete the mating connection. The standard C1M2 is attached to a 5 foot cable with a retaining ring included, but connectors can be fabricated with any length of cable required.

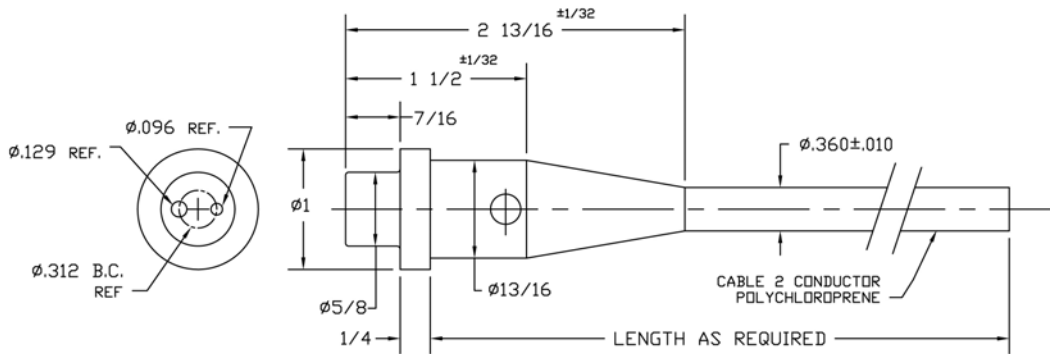

Outline Drawing of a C1M2 Male Connector for Mating to Massa Underwater Transducers (without retaining ring)

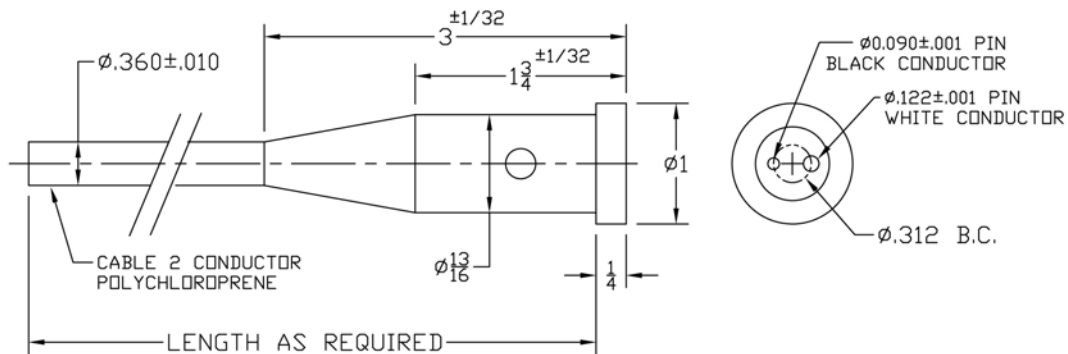

Outline Drawing of a C1F2 Female Connector Supplied on Massa Underwater Transducers (without retaining ring)

MASSA PRODUCTS CORPORATION

280 Lincoln St., Hingham, MA 02043 U.S.A.

Tel: 781-749-4800 Fax: 781-740-2045

Toll Free in USA: 800-962-7543

E-mail: sales@massa.com

Web Site: www.massa.com